

SERVICE • VALUE

**BEST**  
CONVEYORS

**BEST fluid loading/unloading systems  
can improve the efficiency  
of your business**



**BestReach®  
Telescopic Boom**

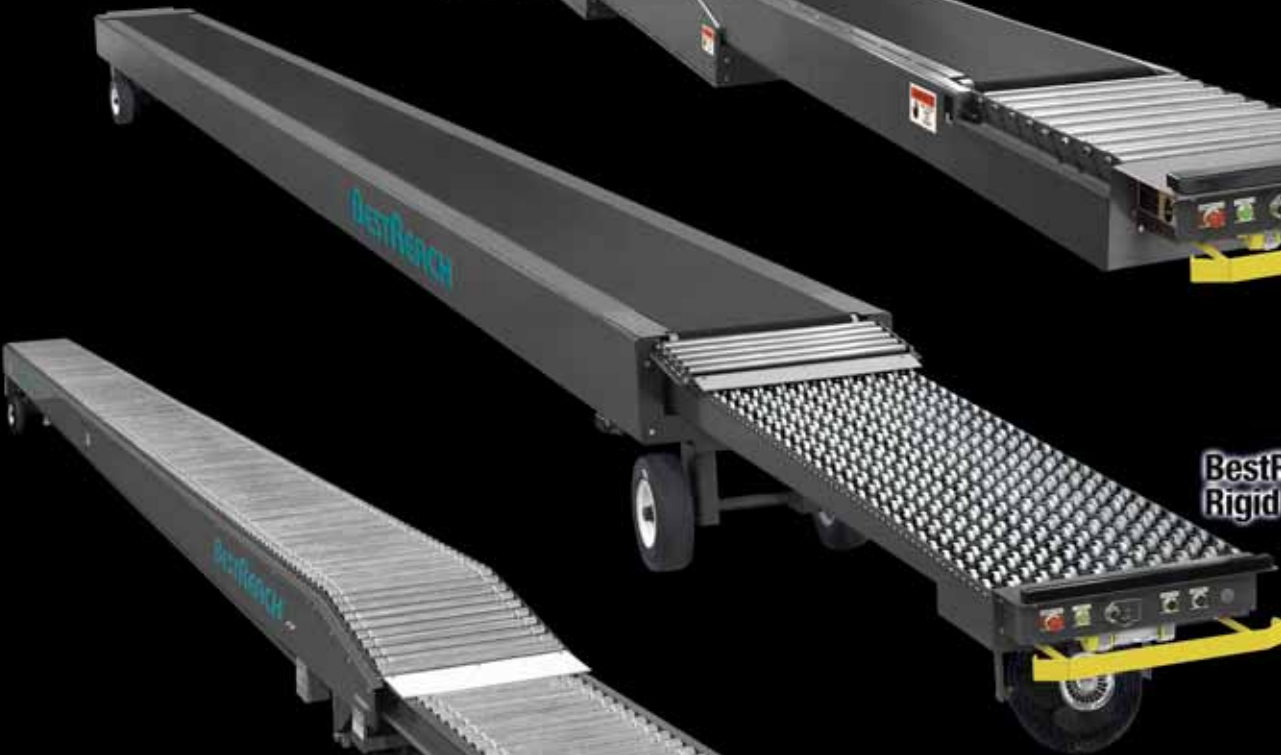

**BestReach®  
Rigid Belt**



**BestReach®  
Rigid Roller**



**Best/Flex®  
Skatewheel**



**Best/Flex®  
Roller**

# BEST Fluid Loading/Unloading Systems Improve the Efficiency of Your Business

Best Conveyors is recognized as the premier supplier of fluid loading/unloading systems worldwide. The key to our success is a total commitment to customer satisfaction. This business philosophy has



*Typical BEST/FLEX® Power conveyor installation.*

placed our equipment in the distribution centers and stores of America's top retailers. To our customers we say "thank you" for your confidence in our products and for your loyalty over the years. To our prospective customers we ask for the opportunity to prove that we offer the BEST Innovation, the BEST Quality, the BEST Service and the BEST Value with every fluid loading/unloading system we deliver.

## BEST INNOVATION

You already know BEST as the undisputed leader in the heavy and standard duty expandable conveyor market. Now, with the introduction of our BestReach conveyors, you will come to know us as the industry leader in the rigid fluid loading market. These new models extend automated loading and unloading all the way into the nose of your trailers. It's the perfect choice for high volume shipping & receiving applications.

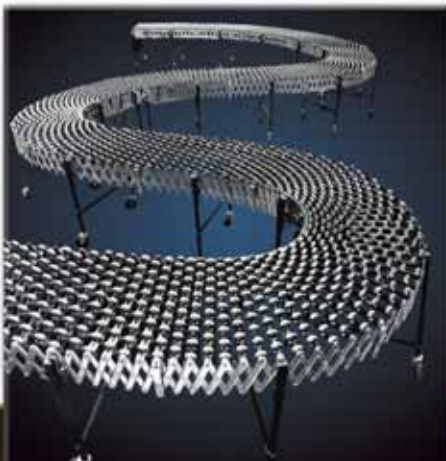

*The original BEST/FLEX® flexible expandable conveyor.*

accumulation so your cartons do not push against each other as they move to the end of the line. Our indexing feature spaces cartons evenly for accurate bar code reading and easier handling. SuperOptics integrates with your existing system to give you the ultimate in automated flow control.

## BEST QUALITY

Quality isn't just a "buzz-word" at BEST. It's the only word. Everything is built to last. Please don't confuse our

conveyors with other brands. BEST conveyors are loaded with features that set us above the competition:

- Structural steel support across the entire conveyor width makes our product more durable than the competition. This patented design is only available from BEST.
- Heavy duty square tubing legs give you greater stability and longer service life.
- Heavy duty, high tensile aluminum side plates feature a unique ribbed design for even greater conveyor strength.
- Perpendicular Legs allow the conveyor legs to remain perpendicular to the floor in both the expanded and compacted positions. This provides

greater mobility, strength and stability—especially in truck loading and unloading operations. Another innovation we are particularly proud of is our improved SuperOptics electronic product flow controls. This exciting technology gives you true zero-pressure

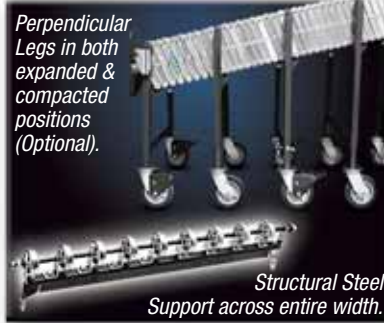

*Perpendicular Legs in both expanded & compacted positions (Optional).*

*Structural Steel Support across entire width.*

## BEST SERVICE

Total Customer Support is the foundation of our business. We design, build and install custom systems to meet the specific needs of our customers. You get excellent support before, during and after the sale—from the factory and in the field. If you need help with an installation, we are there. In fact, we install more than 90% of our systems. We know that every installation is unique, and we use this knowledge to create a seamless transition between your fixed conveyor

and your BEST system. For example, we can place a switch on the BEST conveyor to control an automatic stop on your fixed conveyor. When our technicians install your equipment, they work through any issues to ensure smooth product flow from your fixed conveyor all the way into the nose of your trailers.

## BEST VALUE

To compete in today's business climate, you need to get the highest value from every dollar. BEST helps you achieve this goal in two very meaningful ways.

First, our products offer a true return on your investment because fewer workers accomplish more in less time. In a typical distribution center, the labor savings alone more than pays for the system. Second, our conveyors are built to deliver lasting performance even in the punishing conditions often associated with shipping & receiving applications. So you get the cost saving benefits over a longer period of time.





BEST bridges the gap between permanent conveyors and trailers for faster loading and unloading. Perfect for fluid loading and cross-docking.

### Applications

#### FLUID LOADING AND UNLOADING

Innovative managers are realizing the benefits of fluid loading and unloading. Wherever possible these managers abandon their fork lifts and pallets for a BEST fluid loading/unloading system. With fluid loading you utilize every square inch of your trailers, eliminating the costly "dead-space" wasted by pallets. It's a great way to improve the efficiency of your business.

#### CROSS DOCKING

BEST conveyors are also used in cross-docking applications to move cartons from one truck to another or to a take-away conveyor for immediate routing to shipping.

#### RECEIVING AT THE STORE LEVEL

BEST conveyors are ideal for loading and unloading at the dock door. But even if you do not have a loading dock BEST offers a solution. With the perpendicular leg option BEST/FLEX® gravity conveyors reach from ground level to the truck bed for easy loading and unloading.

Whatever your application, when you specify BEST you can be confident that you are getting the BEST Innovation, the BEST Quality, and the BEST Service in the industry—at a very competitive price. We believe this all adds up to be the BEST Value in the business, and our customers certainly agree!

### Bridging the Gap

When your high technology automated conveyor system stops 12 ft short of the dock door, BEST offers the perfect solution to bridge the gap and continue the automation all the way into the nose of your trailers.

BEST/FLEX® power and gravity expandable conveyors store conveniently under your permanent conveyors when not in use. Then they expand into the trailer for fast loading and unloading.

The BestReach® rigid conveyor systems are available in roller, belt and boom models. These rugged workhorses are made to handle the toughest jobs with ease. They are the perfect choice for fluid loading and unloading in high volume shipping & receiving applications.

Whether you are fluid loading or unloading at a major distribution center, cross docking or receiving merchandise at a store, BEST can help you get the job done quickly, efficiently and economically.



Check out the BESTREACH® rigid conveyors on pages 4 through 7. They offer the perfect solution for high volume fluid loading and unloading applications.



**BESTREACH® Boom**  
Page 4



**BESTREACH® Rigid Roller & Belt**  
Page 6



**Best/Flex® 1.9 Power**  
Page 8



**Best/Flex® 1.5 Power**  
Page 10



**Best/Flex® Roller Gravity**  
Page 12



**Best/Flex® 300 Gravity**  
Page 14



**Best/Flex® 200 Gravity**  
Page 16



**Best/Flex® Ultra Gravity**  
Page 18



**Performance Options**  
Page 20





## BestReach<sup>®</sup> Telescopic Boom Conveyor

### Power Applications

You already know BEST as the leader in the expandable conveyor market. Now, with the introduction of our BestReach<sup>®</sup> Telescopic Boom conveyor, you will come to know us as the industry leader in this important market!

This conveyor extends automated loading all the way into the nose of your trailer. It's the perfect choice for high volume shipping/receiving applications.

Call today and see why more material handling professionals depend on BEST than ever before!



1-800-327-9209  
[www.bestconveyors.com](http://www.bestconveyors.com)



**STANDARD SPECIFICATIONS**

Three standard models available:

88' extended length (25' retracted length)

80' extended length (25' retracted length)

72' extended length (25' retracted length)

- Overall Width .....47 1/2"
- Belt Width .....24"
- Base Belt Height .....42"
- Belt Speed .....60 FPM
- In & Out Speed .....60 FPM
- Capacity Per Linear Foot .....50 lbs.
- Max Capacity .....1,500 lbs. over 30 ft.
- Electrical Requirements.....480 VAC 3 Phase
- Package stop dry contact
- Safety stop on discharge end
- Electronic package stop
- E-Stop Interlocks
- Consult factory for other telescopic boom conveyor models

**Reach from your permanent conveyor all the way into your trailers with ease!**

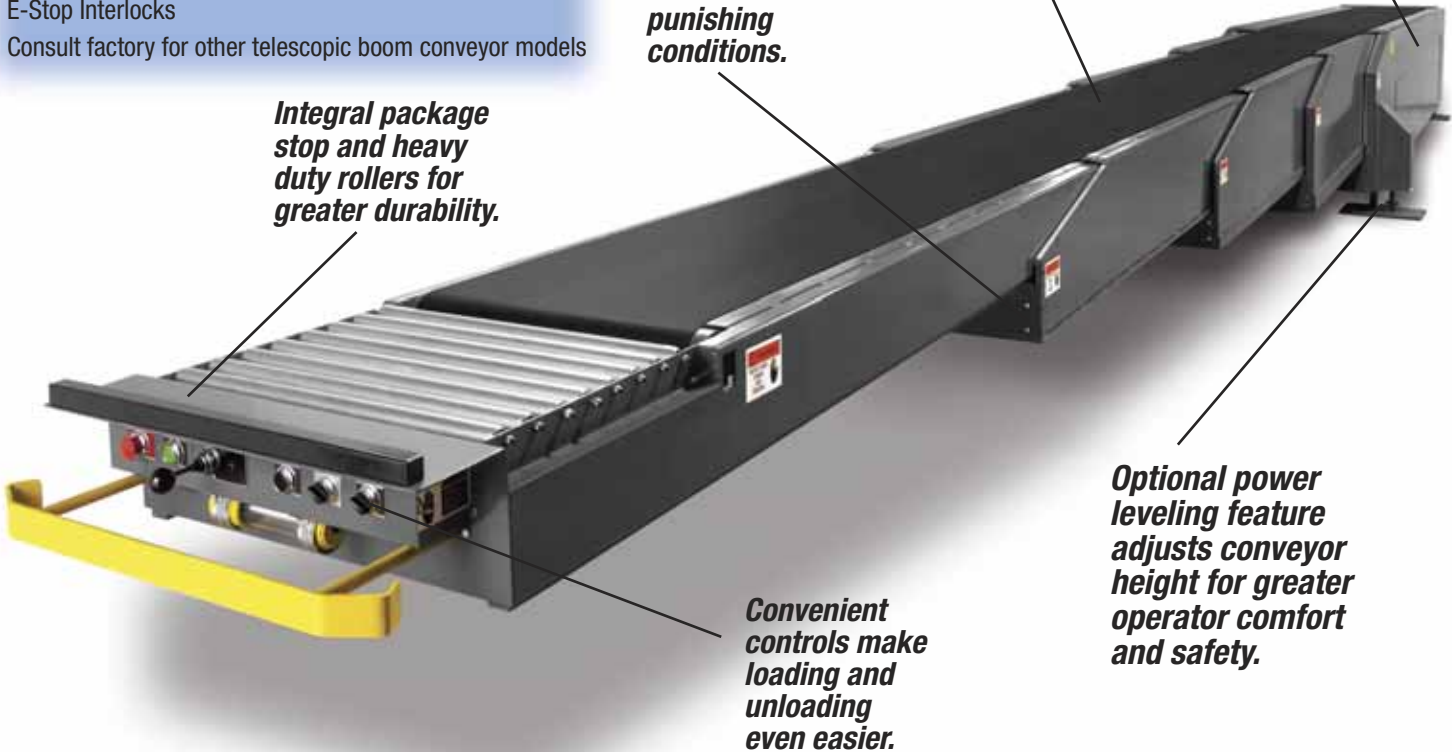

*Integral package stop and heavy duty rollers for greater durability.*

*Heavy duty construction from end to end to withstand punishing conditions.*

*Reinforced rubber belt for extended life.*

*Stores out of the way under your permanent conveyor when not in use.*

*Optional power leveling feature adjusts conveyor height for greater operator comfort and safety.*

*Convenient controls make loading and unloading even easier.*

**PERFORMANCE OPTIONS**

- Power Leveling - Hydraulic/Screw
- Electronic Indexing
- Variable Belt Speed 60-135 FPM
- Light at Discharge End
- Fan at Discharge End
- 240 VAC 3 Phase
- Raised Belt Transfer
- Tilt & Non-Tilt Traversing



# BestReach® Rigid Belt & Rigid Roller Drive-In Conveyors



Belt Drive

Roller Drive

Pull-Out Extension

Pull-Out Extension



- Reach from your permanent conveyor all the way into your trailers with ease
- Power in-and-out with no operator effort for improved ergonomics
- “Bullet-Proof” steel construction withstands punishing conditions and hard impacts

1-800-327-9209

[www.bestconveyors.com](http://www.bestconveyors.com)

## BestReach® Rigid Belt

### STANDARD FEATURES & SPECIFICATIONS

- Five standard conveyor models available:
  - 65' model with 52' base unit and 13' fixed extension
  - 60' model with 52' base unit and 8' fixed extension
  - 57' model with 52' base unit and 5' fixed extension
  - 28' to 38' model with 10' pull out extension
  - 52' to 62' model with 10' pull out extension
- Overall width (approx.) 33 in.
- Belt width (approx.) 24 in.
- Left to right steering with joy stick 5° to 6°
- Minimum top of belt height 32 in.
- Belt speed 60 FPM
- In and out travel speed (approx.) 60 FPM
- Heavy duty motor 1.5 HP
- Capacity per linear foot 100 lbs.
- Maximum line load at any given time 1,000 lbs.
- Electrical requirements 480 VAC 3 Phase
- Large 17" solid rubber tires never go flat and easily move over uneven floors and dock plates
- Guide track keeps unit aligned under feeder conveyor
- Safety stop on discharge end
- Electronic package stop
- E-stop interlocks

### PERFORMANCE OPTIONS

- Discharge elevation 28" to 42" in one inch increments
- Custom lengths available, consult factory
- Belt speed available in 60 to 135 FPM
- Fan at discharge end for operator comfort
- Light at discharge end for added safety
- Electronic indexing
- Manual steering
- 240 VAC 3 Phase

## BestReach® Rigid Roller

### STANDARD FEATURES & SPECIFICATIONS

- Seven standard models available with pull-out extension:
  - 37' extended length model (25' retracted length)
  - 41' extended length model (29' retracted length)
  - 45' extended length model (33' retracted length)
  - 49' extended length model (37' retracted length)
  - 53' extended length model (41' retracted length)
  - 58' extended length model (45' retracted length)
  - 62' extended length model (49' retracted length)
- Overall width (approx.) 33.5 in.
- Roller width (approx.) 29 in.
- Ground clearance 12 in.
- Left to right steering with joy stick 5° to 6°
- Fixed infeed height 36" to 48"
- Fixed discharge height 28" to 40"
- Bed speed 0 to 120 FPM
- Axle centers 3 in.
- Accumulation zone lengths 40" to 49"
- In and out travel speed (approx.) 60 FPM
- Heavy duty motor 1.5 HP
- Capacity per linear foot 100 lbs.
- Maximum line load at any given time 1,000 lbs.
- Electrical requirements 480 VAC 3 Phase
- Large 17" solid rubber tires never go flat and easily move over uneven floors and dock plates
- Dry contact to feeder conveyor for emergency stop
- Input from feeder conveyor for emergency stop
- Interlock signal to feeder conveyor for full line

### PERFORMANCE OPTIONS

- Fan at discharge end for operator comfort
- Light at discharge end for added safety
- Variable 0-200 FPM bed speed
- 4.5" axle centers
- 240 VAC 3 Phase

Fixed Extension



*In addition to the above standard sizes, BestReach® conveyors can be constructed in custom lengths tailored to your specific application. You can order your Bestreach conveyors in roller or belt models with pullout or fixed extensions. Whatever it takes to get the job done.*







## Best/Flex® Power 1.9 Roller

### Power Applications

Ideally suited for truck loading and unloading, distribution centers, packaging, portable assembly lines, shipping and receiving.

Move in and out of trucks with POWERTRAX for faster, safer, easier loading and unloading. See back cover.

- 100 lbs. capacity per linear ft. (level)
- 28½" to 37¼" adjustable conveyor height
- 18", 24" and 30" conveyor widths
- Available in any length to fit your applications

The above conveyor is equipped with the zero-pressure accumulation option using Read-Between-the-Rollers photo cells.

1-800-327-9209

[www.bestconveyors.com](http://www.bestconveyors.com)



**SPECIFICATIONS**

	Model Number	Standard Lengths Compacted to Expanded	Leg Sets Per Unit	Roller Axle Centers EXTENDED	Approx. Shipping Weight
<b>16" WIDTHS</b>	B/FP(1.9)-18-12	5' to 12'	5	5"	414 lbs.
	B/FP(1.9)-18-24	10' to 24'	8	5"	803 lbs.
	B/FP(1.9)-18-36	15' to 36'	11	5"	1,190 lbs.
	B/FP(1.9)-18-48	20' to 48'	14	5"	1,605 lbs.
<b>24" WIDTHS</b>	B/FP(1.9)-24-12	5' to 12'	5	5"	474 lbs.
	B/FP(1.9)-24-24	10' to 24'	8	5"	939 lbs.
	B/FP(1.9)-24-36	15' to 36'	11	5"	1,366 lbs.
	B/FP(1.9)-24-48	20' to 48'	14	5"	1,878 lbs.
<b>30" WIDTHS</b>	B/FP(1.9)-30-12	5' to 12'	5	5"	546 lbs.
	B/FP(1.9)-30-24	10' to 24'	8	5"	1,048 lbs.
	B/FP(1.9)-30-36	15' to 36'	11	5"	1,568 lbs.
	B/FP(1.9)-30-48	20' to 48'	14	5"	2,097 lbs.

**Adjustable Height:** Standard adjustable range is from 28 1/2" to 37 1/4".

**Axle Centers:** When expanded, the distance between axle centers is 5". Optional 3" and 4" axle centers are available. Optional axle centers affect compacted conveyor length and shipping weights. Call our Sales Team for assistance.

**Extended Lengths:** BEST/FLEX Power conveyors are available in any length. If your application requires a length not listed in the above chart, call our Sales Team for assistance.

**FEATURES**

- **Continuous Duty Multiple Drive Motors**— Line speed is adjustable from 0 to 120 ft. per minute. Start/Stop cycle 300 times per hour. On/Off switches at both ends. Approximately 3 amps per 12 ft. of conveyor. Durable DC drive motors with 120VAC. Optional 230VAC available.
- **Self Tracking**—Cartons follow the twists and turns of the conveyor path without using engineered curves.
- **Adjustable Height**—Simply turn the locking knob to raise or lower the conveyor bed height.
- **Square Tubing Legs**—BEST was the first to offer heavy duty square tubing legs for longer service life.
- **1.9 Rollers**—Heavy duty 16 gauge precision bearing rollers on 12 mm axles for greater durability.
- **2" Side Plates**—Aluminum alloy construction features a ribbed design for added strength. Assembled with bolts and lock nuts.
- **Casters with brakes**—Colson 8" x 2" swivel casters roll easily over uneven surfaces. Caster brakes lock wheels in place while the conveyor is in use.

**PERFORMANCE OPTIONS**

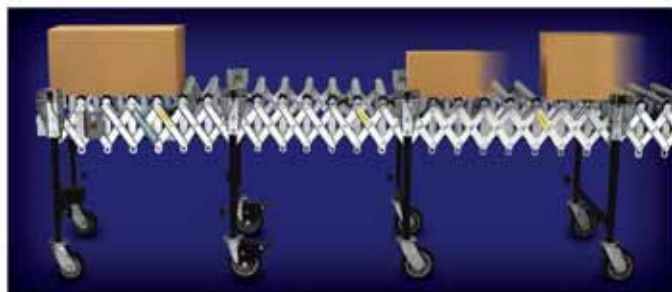

**SuperOptics™ Electronics for Product Control.**

Gives BEST/FLEX® POWER conveyors superior product flow control and improved ergonomics to cut labor costs and improve performance. Using Reflective or Read-Between-The-Rollers photo cells you can get the benefits of zero-pressure accumulation and an electronic package stop. Read more about these important options on the back cover.



**Electronic Package Stop.**  
Automatically stops cartons at discharge end of conveyor. When carton is removed, conveyor starts again to bring next carton into position.

**Zero-Pressure Accumulation.**

Electronic controls enable cartons to move directly to the discharge end without stopping until they reach the last zone of accumulation.



**Indexing.**  
Reflective photo cells allow you to control the space between cartons for easier handling and bar code reading.

**Leg Connect Brackets.**  
Easily connects two or more conveyors to span greater distances.



**Axle Centers.**  
Optional 3" and 4" axle centers are available for small package applications.



This product is Listed to applicable UL standards and requirements by Underwriters Laboratories Inc. for US and Canadian safety standards.

Please contact us for details regarding your application.



## Best/Flex® Power 1.5 Roller

### Power Applications

Ideally suited for truck loading and unloading, distribution centers, packaging, portable assembly lines, shipping and receiving.

Move in and out of trucks with POWERTRAX for faster, safer, easier loading and unloading. See back cover.

- 100 lbs. capacity per linear ft. (level)
- 31½" to 44½" adjustable conveyor height
- 18", 24" and 30" conveyor widths
- Available in any length to fit your applications

The above conveyor is equipped with the electronic package stop option using reflective photo cells.

1-800-327-9209

[www.bestconveyors.com](http://www.bestconveyors.com)



**SPECIFICATIONS**

	Model Number	Standard Lengths Compacted to Expanded	Leg Sets Per Unit	Roller Axle Centers EXTENDED	Approx. Shipping Weight
<b>16" WIDTHS</b>	B/FP(1.5)-18-12	4' to 12'	5	5"	354 lbs.
	B/FP(1.5)-18-24	8' to 24'	8	5"	707 lbs.
	B/FP(1.5)-18-36	12' to 36'	11	5"	1,083 lbs.
	B/FP(1.5)-18-48	16' to 48'	14	5"	1,415 lbs.
<b>24" WIDTHS</b>	B/FP(1.5)-24-12	4' to 12'	5	5"	415 lbs.
	B/FP(1.5)-24-24	8' to 24'	8	5"	815 lbs.
	B/FP(1.5)-24-36	12' to 36'	11	5"	1,248 lbs.
	B/FP(1.5)-24-48	16' to 48'	14	5"	1,630 lbs.
<b>30" WIDTHS</b>	B/FP(1.5)-30-12	4' to 12'	5	5"	494 lbs.
	B/FP(1.5)-30-24	8' to 24'	8	5"	936 lbs.
	B/FP(1.5)-30-36	12' to 36'	11	5"	1,437 lbs.
	B/FP(1.5)-30-48	16' to 48'	14	5"	1,871 lbs.

**Adjustable Height:** Standard adjustable range is from 31½" to 44½". 8 inch caster option adds 2" to conveyor height to make adjustable range from 33½" to 46½".

**Axle Centers:** When expanded, the distance between axle centers is 5". Optional 3" and 4" axle centers are available. Optional axle centers affect compacted conveyor length and shipping weights. Call our Sales Team for assistance.

**Extended Lengths:** BEST/FLEX Power 1.5 conveyors are available in any length. If your application requires a length not listed in the above chart, call our Sales Team for assistance.

**FEATURES**

- **Continuous Duty Multiple Drive Motors**— Line speed is adjustable from 0 to 120 ft. per minute. Start/Stop cycle 300 times per hour. On/Off switches at both ends. Approximately 3 amps per 12 ft. of conveyor. Durable DC drive motors with 120VAC. Optional 230VAC available.
- **Self Tracking**—Cartons follow the twists and turns of the conveyor path without using engineered curves.
- **Adjustable Height**—Simply turn the locking knob to raise or lower the conveyor bed height.
- **Square Tubing Legs**—BEST was the first to offer heavy duty square tubing legs for longer service life.
- **1.5 Rollers**—Heavy duty 16 gauge precision bearing rollers on 12 mm axles for greater durability.
- **1.59" Side Plates**—Aluminum alloy construction features a ribbed design for added strength. Assembled with bolts and lock nuts.
- **Casters with brakes**—Colson 6" x 2" swivel casters roll easily. Caster brakes lock wheels in place while the conveyor is in use.



This product is Listed to applicable UL standards and requirements by Underwriters Laboratories Inc. for US and Canadian safety standards.

Please contact us for details regarding your application.

**PERFORMANCE OPTIONS**

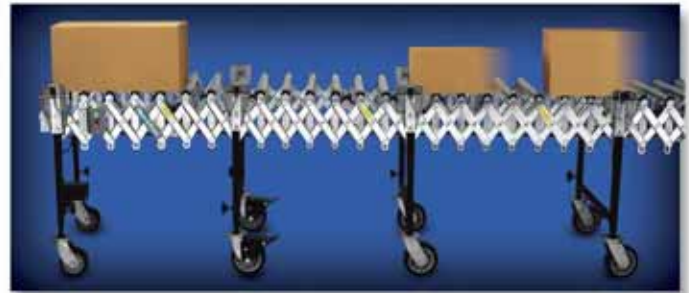

**SuperOptics™ Electronics for Product Control.**

Gives BEST/FLEX® POWER conveyors superior product flow control and improved ergonomics to cut labor costs and improve performance. Using Reflective or Read-Between-The-Rollers photo cells you can get the benefits of zero-pressure accumulation and an electronic package stop. Read more about these important options on the back cover.

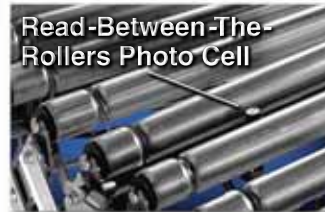

**Electronic Package Stop.**  
Automatically stops cartons at discharge end of conveyor. When carton is removed, conveyor starts again to bring next carton into position.

**Zero-Pressure Accumulation.**

Electronic controls enable cartons to move directly to the discharge end without stopping until they reach the last zone of accumulation.



**Indexing.**

Reflective photo cells allow you to control the space between cartons for easier handling and bar code reading.

**Leg Connect Brackets.**  
Easily connects two or more conveyors to span greater distances.



**Axle Centers.**

Optional 3" and 4" axle centers are available for small package applications.

**Colson 8" x 2" Swivel Casters.**

For easier rolling over uneven surfaces. Adds 2" to the conveyor height.





## Best/Flex® Roller

### Gravity Applications

Excellent for handling odd shaped boxes, bags and low grade corrugated cartons that could get hung up on skatewheel conveyors.

Move in and out of trucks with POWERTRAX for faster, safer, easier loading and unloading. See back cover.

- 150 lbs. capacity per linear ft.
- 1<sup>3</sup>/<sub>8</sub>" rollers
- 30" to 42<sup>1</sup>/<sub>2</sub>" adjustable conveyor height
- 18", 24" and 30" conveyor widths
- Available in any length to fit your applications

The above conveyor is equipped with an optional package stop that folds out of the way when not needed.

1-800-327-9209  
[www.bestconveyors.com](http://www.bestconveyors.com)



**SPECIFICATIONS**

	Model Number	Standard Lengths Compacted to Expanded	Leg Sets Per Unit	Roller Axle Centers EXTENDED	Approx. Shipping Weight
<b>16" WIDTHS</b>	B/FR-18-12	4' to 12'	4	5"	225 lbs.
	B/FR-18-16	5'4" to 16'	5	5"	290 lbs.
	B/FR-18-20	6'8" to 20'	6	5"	360 lbs.
	B/FR-18-24	8' to 24'	7	5"	425 lbs.
<b>24" WIDTHS</b>	B/FR-24-12	4' to 12'	4	5"	240 lbs.
	B/FR-24-16	5'4" to 16'	5	5"	305 lbs.
	B/FR-24-20	6'8" to 20'	6	5"	375 lbs.
	B/FR-24-24	8' to 24'	7	5"	440 lbs.
<b>30" WIDTHS</b>	B/FR-30-12	4' to 12'	4	5"	255 lbs.
	B/FR-30-16	5'4" to 16'	5	5"	320 lbs.
	B/FR-30-20	6'8" to 20'	6	5"	390 lbs.
	B/FR-30-24	8' to 24'	7	5"	455 lbs.

**Adjustable Height:** Standard adjustable range is from 30" to 42 1/2". 6 inch caster option adds 1 1/2" to conveyor height to make adjustable range from 31 1/2" to 44". 8 inch caster option adds 3 1/2" to conveyor height to make adjustable range from 33 1/2" to 46".

**Axle Centers:** When expanded, the distance between axle centers is 5". Optional 3" and 4" axle centers are available. Optional axle centers affect compacted conveyor length and shipping weights. Call our Sales Team for assistance.

**Extended Lengths:** BEST/FLEX Gravity Roller conveyors are available in any length. If your application requires a length not listed in the above chart, call our Sales Team for assistance.

**FEATURES**

- **Self Tracking**—Cartons follow the twists and turns of the conveyor path without using engineered curves.
- **Adjustable Height**—Simply turn the locking knob to raise or lower the conveyor bed height.
- **Square Tubing Legs**—BEST was the first to offer heavy duty square tubing legs for longer service life.
- **1 1/2" Side Plates**—Aluminum alloy construction features a ribbed design for added durability. Assembled with bolts and lock nuts.
- **Casters with brakes**—Colson 5" x 1 1/4" swivel casters roll easily. Caster brakes lock both wheel and swivel simultaneously while the conveyor is in use.

**PERFORMANCE OPTIONS**



**Package Stop.**  
Stops cartons at the end of the conveyor and folds down out of the way when not needed.



**Side Rails.**  
Prevents cartons from skewing off the conveyor in accumulation applications.



**Leg Connect Brackets.**  
Easily connects two or more conveyors to span greater distances.



**Axle Centers.**  
Optional 3" and 4" axle centers are available for small package applications.



**Colson 6" x 2" Swivel Casters.**  
For easier rolling over uneven surfaces. Adds 1 1/2" to the conveyor height.



**Heavy Duty Option.**  
BEST/FLEX Roller conveyors are available with heavy duty 1.9" rollers. Call our Sales Team for assistance.



## Best/Flex 300

### Gravity Applications

Built tough to handle applications running three shifts per day. Ideally suited for truck loading and unloading, distribution centers, shipping and receiving. The optional Impact Support Section is recommended for high impact receiving applications.

Move in and out of trucks with POWERTRAX for faster, safer, easier loading and unloading. See back cover.

- 300 lbs. capacity per linear ft.
- 28<sup>1</sup>/<sub>2</sub>" to 41<sup>1</sup>/<sub>2</sub>" adjustable conveyor height
- 18", 24" and 30" conveyor widths
- Available in any length to fit your applications

The above conveyor is equipped with an optional package stop that folds out of the way when not needed.

1-800-327-9209

[www.bestconveyors.com](http://www.bestconveyors.com)



**SPECIFICATIONS**

	Model Number	Standard Lengths Compacted to Expanded	Leg Sets Per Unit	Skate Wheels Per Axle	Approx. Shipping Weight
<b>16" WIDTHS</b>	B/F300-18-12	4' to 12'	4	7	232 lbs.
	B/F300-18-16	5'4" to 16'	5	7	325 lbs.
	B/F300-18-20	6'8" to 20'	6	7	390 lbs.
	B/F300-18-24	8' to 24'	7	7	463 lbs.
<b>24" WIDTHS</b>	B/F300-24-12	4' to 12'	4	9	271 lbs.
	B/F300-24-16	5'4" to 16'	5	9	370 lbs.
	B/F300-24-20	6'8" to 20'	6	9	446 lbs.
	B/F300-24-24	8' to 24'	7	9	527 lbs.
<b>30" WIDTHS</b>	B/F300-30-12	4' to 12'	4	10	328 lbs.
	B/F300-30-16	5'4" to 16'	5	10	427 lbs.
	B/F300-30-20	6'8" to 20'	6	10	514 lbs.
	B/F300-30-24	8' to 24'	7	10	604 lbs.

**Adjustable Height:** Standard adjustable range is from 28 1/2" to 41 1/2". 6 inch caster option adds 1 1/2" to conveyor height to make adjustable range from 30" to 43".

**Axle Centers:** When expanded, the distance between axle centers is 5". Optional 3" and 4" axle centers are available. Optional axle centers affect compacted conveyor length and shipping weights.. Call our Sales Team for assistance.

**Extended Lengths:** BEST/FLEX 300 conveyors are available in any length. If your application requires a length not listed in the above chart, call our Sales Team for assistance. We will help you select the perfect conveyor and options for your application.

**FEATURES**

- **Self Tracking**—Cartons follow the twists and turns of the conveyor path without using engineered curves.
- **Adjustable Height**—Simply turn the locking knob to raise or lower the conveyor bed height.
- **Square Tubing Legs**—BEST was the first to offer heavy duty square tubing legs for longer service life.
- **1 1/2" Side Plates**—Aluminum alloy construction features a ribbed design for added durability. Assembled with bolts and lock nuts.
- **Structural Steel Support**—Channel steel spans the entire conveyor width for unequalled strength. You can only get this patented design from BEST.
- **Casters with brakes**—Colson 5" x 1 1/4" swivel casters roll easily. Caster brakes lock both wheel and swivel simultaneously while the conveyor is in use.

**PERFORMANCE OPTIONS**



**Package Stop.**  
Stops cartons at the end of the conveyor and folds down out of the way when not needed.



**Impact Support Section.**  
Built into the conveyor—not an add-on. Offers extra support to handle punishing conditions.



**Leg or Axle Connect Brackets.**  
Easily connects two or more conveyors to span greater distances.



**Axle Centers.**  
Optional 3" and 4" axle centers are available for small package applications.



**Skatewheels.**  
You can choose steel wheels or HDPE plastic wheels with ball bearings for easier rolling or polyolefin wheels with brass bushings.

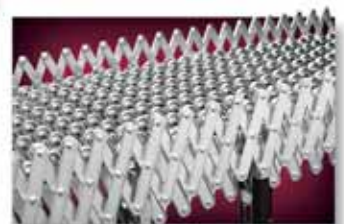

**Side Rails.**  
Prevents cartons from skewing off the conveyor in accumulation applications.



**Colson 6" x 2" Swivel Casters.**  
For easier rolling over uneven surfaces. Adds 1 1/2" to the conveyor height.



**Perpendicular Legs**  
Keeps legs vertical in both the expanded and compacted positions for easier mobility and added strength.

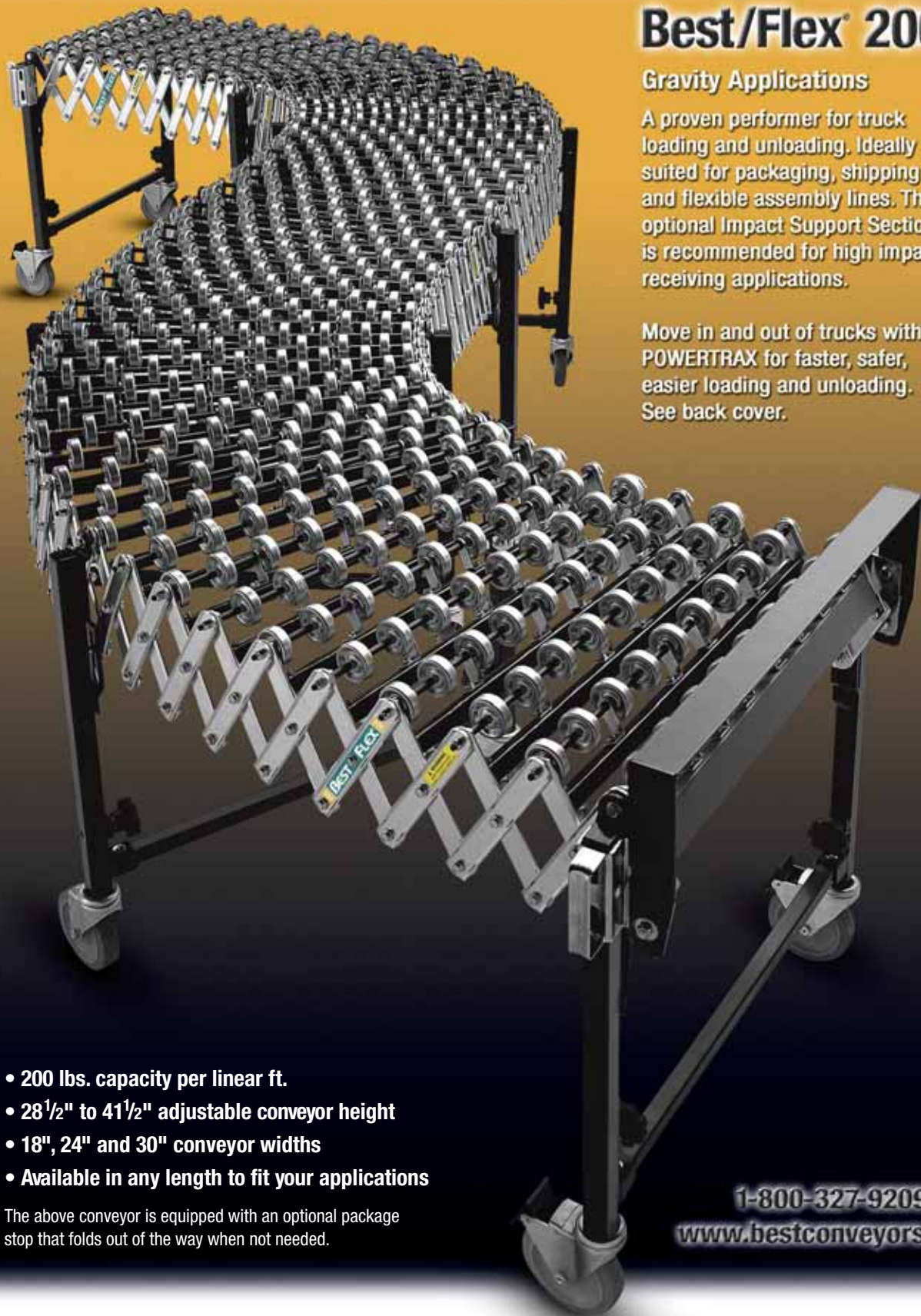

## Best/Flex® 200

### Gravity Applications

A proven performer for truck loading and unloading. Ideally suited for packaging, shipping and flexible assembly lines. The optional Impact Support Section is recommended for high impact receiving applications.

Move in and out of trucks with POWERTRAX for faster, safer, easier loading and unloading. See back cover.

- 200 lbs. capacity per linear ft.
- 28½" to 41½" adjustable conveyor height
- 18", 24" and 30" conveyor widths
- Available in any length to fit your applications

The above conveyor is equipped with an optional package stop that folds out of the way when not needed.

1-800-327-9209  
[www.bestconveyors.com](http://www.bestconveyors.com)



**SPECIFICATIONS**

	Model Number	Standard Lengths Compacted to Expanded	Leg Sets Per Unit	Skate Wheels Per Axle	Approx. Shipping Weight
<b>18" WIDTHS</b>	B/F200-18-12	3' to 12'	4	7	222 lbs.
	B/F200-18-16	4' to 16'	5	7	312 lbs.
	B/F200-18-20	5' to 20'	6	7	373 lbs.
	B/F200-18-24	6' to 24'	7	7	434 lbs.
<b>24" WIDTHS</b>	B/F200-24-12	3' to 12'	4	9	259 lbs.
	B/F200-24-16	4' to 16'	5	9	354 lbs.
	B/F200-24-20	5' to 20'	6	9	426 lbs.
	B/F200-24-24	6' to 24'	7	9	498 lbs.
<b>30" WIDTHS</b>	B/F200-30-12	3' to 12'	4	10	314 lbs.
	B/F200-30-16	4' to 16'	5	10	408 lbs.
	B/F200-30-20	5' to 20'	6	10	491 lbs.
	B/F200-30-24	6' to 24'	7	10	574 lbs.

**Adjustable Height:** Standard adjustable range is from 28 1/2" to 41 1/2". 6 inch caster option adds 1 1/2" to conveyor height to make adjustable range from 30" to 43".

**Axle Centers:** When expanded, the distance between axle centers is 5". Optional 3" and 4" axle centers are available. Optional axle centers affect compacted conveyor length and shipping weights. Call our Sales Team for assistance.

**Extended Lengths:** BEST/FLEX 200 conveyors are available in any length. If your application requires a length not listed in the above chart, call our Sales Team for assistance. We will help you select the perfect conveyor and options for your application.

**FEATURES**

- **Self Tracking**—Cartons follow the twists and turns of the conveyor path without using engineered curves.
- **Adjustable Height**—Simply turn the locking knob to raise or lower the conveyor bed height.
- **Square Tubing Legs**—BEST was the first to offer heavy duty square tubing legs for longer service life.
- **1 1/4" Side Plates**—Aluminum alloy construction features a ribbed design for added durability. Assembled with bolts and lock nuts.
- **Structural Steel Support**—Channel steel spans the entire conveyor width for unequalled strength. You can only get this patented design from BEST.
- **Casters with brakes**—Colson 5" x 1 1/4" swivel casters roll easily. Caster brakes lock both wheel and swivel simultaneously while the conveyor is in use.

**PERFORMANCE OPTIONS**



**Package Stop.**  
Stops cartons at the end of the conveyor and folds down out of the way when not needed.

**Impact Support Section.**  
Built into the conveyor—not an add-on. Offers extra support to handle punishing conditions.



**Leg or Axle Connect Brackets.**  
Easily connects two or more conveyors to span greater distances.

**Axle Centers.**  
Optional 3" and 4" axle centers are available for small package applications.



**Skatewheels.**  
You can choose steel wheels or HDPE plastic wheels with ball bearings for easier rolling or polyolefin wheels with brass bushings.

**Side Rails.**  
Prevents cartons from skewing off the conveyor in accumulation applications.



**Colson 6" x 2" Swivel Casters.**  
For easier rolling over uneven surfaces. Adds 1 1/2" to the conveyor height.

**Perpendicular Legs.**  
Keeps legs vertical in both the expanded and compacted positions for easier mobility and added strength.



## Best/Flex<sup>®</sup> ULTRA

### Gravity Applications

You already know BEST as the undisputed leader in the heavy and standard duty expandable conveyor market. Now, with the introduction of our ULTRA conveyor, you will also know us as the leader in the medium weight conveyors! ULTRA is the perfect choice for packaging lines and lighter volume shipping and receiving applications.

- 175 lbs. capacity per linear ft.
- 28<sup>1</sup>/<sub>2</sub>" to 41<sup>1</sup>/<sub>2</sub>" adjustable conveyor height
- 14", 18" and 24" conveyor widths
- Available in any length to fit your applications

1-800-327-9209  
[www.bestconveyors.com](http://www.bestconveyors.com)



**SPECIFICATIONS**

	Model Number	Standard Lengths Compacted to Expanded	Leg Sets Per Unit	Skate Wheels Per Axle	Approx. Shipping Weight
14" WIDTHS	BFU-14-12	3' to 12'	4	5	137 lbs.
	BFU-14-20	5' to 20'	6	5	217 lbs.
	BFU-14-24	6' to 24'	7	5	259 lbs.
	BFU-14-30	7.5' to 30'	9	5	325 lbs.
	BFU-14-36	9' to 36'	11	5	392 lbs.
16" WIDTHS	BFU-18-12	3' to 12'	4	6	149 lbs.
	BFU-18-20	5' to 20'	6	6	236 lbs.
	BFU-18-24	6' to 24'	7	6	282 lbs.
	BFU-18-30	7.5' to 30'	9	6	353 lbs.
	BFU-18-36	9' to 36'	11	6	425 lbs.
24" WIDTHS	BFU-24-12	3' to 12'	4	7	163 lbs.
	BFU-24-20	5' to 20'	6	7	260 lbs.
	BFU-24-24	6' to 24'	7	7	310 lbs.
	BFU-24-30	7.5' to 30'	9	7	388 lbs.
	BFU-24-36	9' to 36'	11	7	467 lbs.

**Adjustable Height:** Standard adjustable range is from 28 1/2" to 41 1/2". 6 inch caster option adds 1 1/2" to conveyor height to make adjustable range from 30" to 43".

**Axle Centers:** When expanded, the distance between axle centers is 5". Optional 3" and 4" axle centers are available. Optional axle centers affect compacted conveyor length and shipping weights. Call our Sales Team for assistance.

**Extended Lengths:** BEST/FLEX ULTRA conveyors are available in any length. If your application requires a length not listed in the above chart, call our Sales Team for assistance. We will help you select the perfect conveyor and options for your application.

**FEATURES**

- **Self Tracking** – Cartons follow the twists and turns of the conveyor path without using engineered curves.
- **Adjustable Height** – Simply turn the locking knob to raise or lower the conveyor bed height.
- **Square Tubing Legs** – BEST was the first to offer heavy duty square tubing legs for longer service life.
- **Side Plates** – Strong 12 gauge formed steel sidebars feature attractive zinc plating to resist corrosion.
- **Steel Axles** – Sturdy 1/2" zinc plated steel axles provide support across the conveyor width.
- **Casters with brakes** – 5" swivel casters roll easily. Side lock brake locks the wheel for greater stability while the conveyor is in use.

**PERFORMANCE OPTIONS**



**Package Stop.**

Stops cartons at the end of the conveyor and folds down out of the way when not needed.



**Leg or Axle Connect Brackets.**

Easily connects two or more conveyors to span greater distances.



**Axle Centers**

**Axle Centers.**

Optional 3" and 4" axle centers are available for small package applications.



**Skatewheels.**

You can choose steel wheels with ball bearings for easier rolling or nylon wheels for greater economy.



**6" x 2" Swivel Casters.**

For easier rolling over uneven surfaces. Adds 1 1/2" to conveyor height.

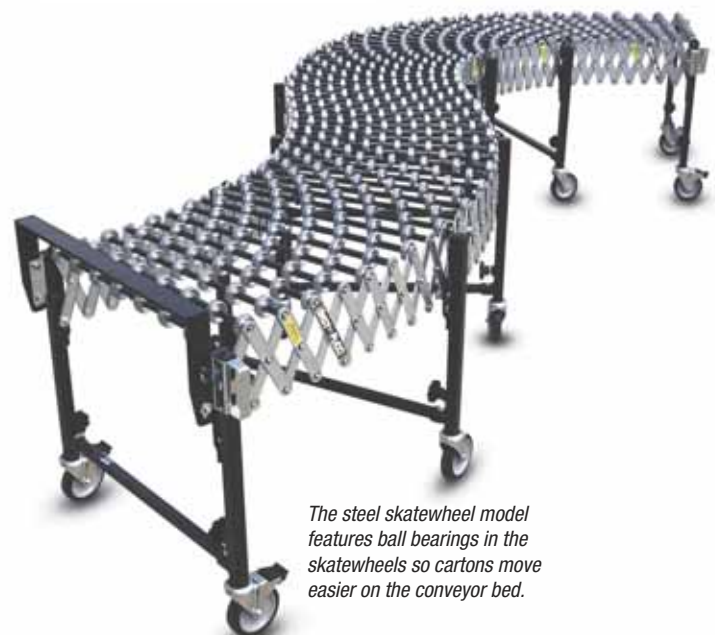

The steel skatewheel model features ball bearings in the skatewheels so cartons move easier on the conveyor bed.

## Performance Options

With our broad product line, years of experience and unequalled expertise, we can help you put together a system that is perfectly integrated with your existing fixed conveyor. This is not a one-size-fits-all business. No two systems are

exactly alike. That's why BEST offers an array of features and options that make fluid loading/unloading faster and more efficient. Call today and see why more material handling professionals depend on BEST than ever before!

### SuperOptics Electronic Flow Controls

- Electronic Package Stop
- Zero-pressure accumulation
- Indexing



PowerTrax

- PowerTrax allows you to electronically power your expandable conveyors in and out of trailers. Saves time, sweat and strain so fewer workers can accomplish more.
- SuperOptics Electronic Controls give BEST power conveyors extra performance features to give you the the ultimate in automated product flow control.

### Hinged Roller Transition

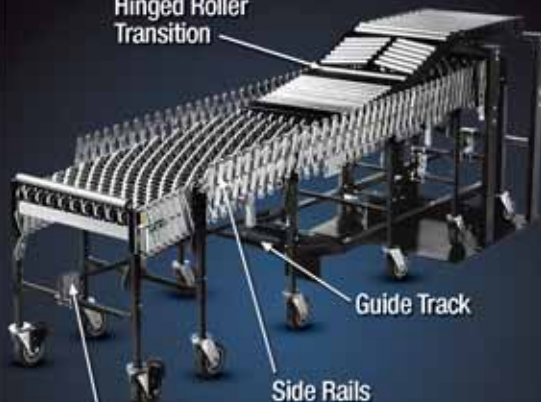

Longitudinal Leg Brace

- Hinged Roller Transitions connect your permanent conveyors to your BEST system so product can flow from your fixed conveyor all the way into your trailers.
- Guide Tracks and Longitudinal Leg Braces make expanding or compacting BEST/FLEX conveyors even easier.
- Side Rails keep odd shaped products from hanging off the side of the conveyor.

### Infeed Impact Cart



Package Stop

- Impact Carts alleviate strain on your expandable conveyor system by absorbing the punishing impacts at the infeed and discharge ends of the conveyor. The heavy duty framework and heavy gauge rollers will add years of life to your fluid loading/unloading system.
- Package stop available for discharge applications.

## Special Applications

### Two-Stage Conveyor

- Two-Stage Conveyors are a great solution for many loading applications. Our technicians ensure smooth product flow from your fixed conveyors all the way into the nose of your trailers.



### Extend-a-Stick

Extend-A-Stick connects to your Best conveyor for dockless receiving applications.



# BEST

CONVEYORS

1-800-327-9209

[www.bestconveyors.com](http://www.bestconveyors.com)

Best Conveyors

107 Flint Street • Jonesboro, AR 72401

Phone: 1-870-935-0970 • Fax: 1-870-935-3661

E-mail: [salesinfo@bestconveyors.com](mailto:salesinfo@bestconveyors.com)

[www.bestconveyors.com](http://www.bestconveyors.com)

Best Conveyors

Brunel Road • Earlstrees Industrial Estate  
Corby, Northants • NN17 4JW - Great Britain

Tel: +44 (0)1536 206969 • Fax: +44 (0)1536 206805

E-mail: [info@bestconveyors.co.uk](mailto:info@bestconveyors.co.uk) • [www.bestconveyors.co.uk](http://www.bestconveyors.co.uk)

LongReach Telescopic Conveyors Pty. Ltd.

6 Capelli Road • Wingfield • South Australia 5013  
Australian Free Call: 1800 819 139

TEL: +61 (8) 8349 4777 • FAX: +61 (8) 8349 5770

E-mail: [enquiries@longreach.au.com](mailto:enquiries@longreach.au.com)