



# Yellow Products

FACILITY ASSET PROTECTION



## Save Your Assets

- Rails
- Systems
- Protectors
- More



**IN STOCK**

"Save'ty"® Stand Guard Rails & Systems



**Protecting The Supply Chain.**

# "Save"ty<sup>®</sup> Yellow Products

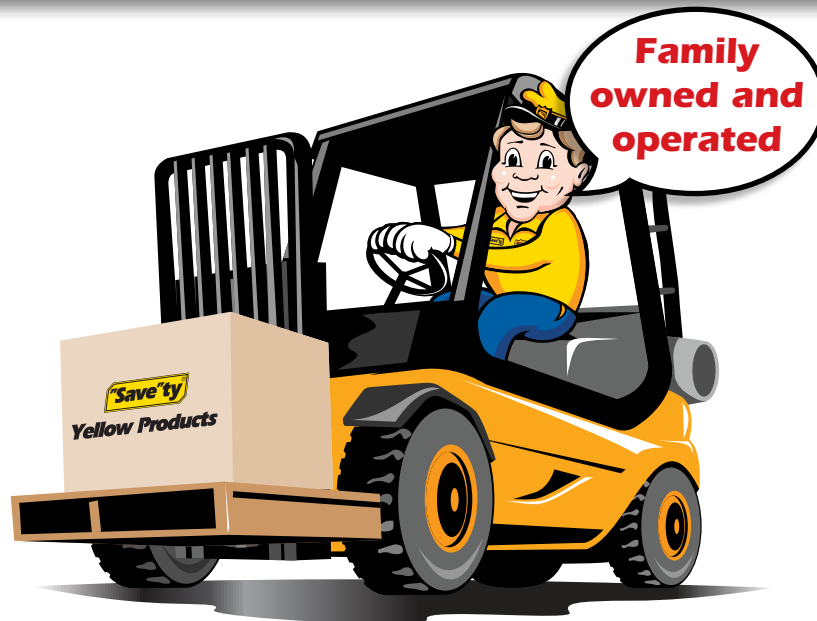

## We Deliver MORE Than Just Our Products!

### We Deliver PEACE OF MIND!

**W**ithout "Save"ty Yellow Products, you may be worrying more about safety issues than you should be.

You have invested in your business – equipment, inventory, and especially employees – to meet the needs of your customers. You don't want unexpected safety issues to cause you downtime, added expense, or personal injury. Let "Save"ty Yellow Products help protect your business and **SAVE YOUR ASSETS!**

Our products have been shown to protect employees, facilities, products, and equipment from impact with forklifts, and do it better and at a lower cost! We have supplied products to facilities used by some of America's finest companies, including Sears, U.S. Foods, Adidas, Home Depot and General Electric.

Built on the foundation of our unique drop-in/lift-out guard rail system, "Save"ty Yellow Products has branched out to include facility protection, hand rails, safety gates and more. We continue to develop

new products to meet safety needs and also customize products for specific applications.

The products we manufacture are made in America, powder coated with certified lead-free paint, and stocked in Illinois.

We invite you to enjoy the peace of mind that comes from knowing that your business is protected 24/7. "Save"ty Yellow Products can help you do that!

– Dan Gentile  
President

## The little things matter...



In Stock



Quality



Packaging

# Guard rails



Double corner post



Inline post



Offset end post

## Ribbed Rail "Stand Guard"

Our most popular item: the **Stand Guard ribbed rail**. All welded **DROP-IN LIFT-OUT** design standard, which reduces installation cost by half!

- Sleeves are welded to posts, **no costly brackets as an afterthought.**
- Posts: 4" (10,000 lbs.) with 10" x 10" x 1/2" base or 5" (12,000 lbs.) with 10" x 10" x 5/8" base, both with painted steel caps.
- Post heights: 18", 26" & 42".
- 10-gage, high-tensile steel rails fit either post.
- Rails are 2' through 10' in 1' increments.

**FULLY WELDED SLEEVES!**

**Offset posts are in stock.**





Lite ribbed guard rail



Create a pedestrian walkway with Stand Guard Lite



Protect walls with durable wall protection



## Lite Duty Guard Rail

"Stand Guard" Lite is designed for powered and manual stackers, electric pallet trucks, steel carts & hoppers, etc.

- A great alternative to high strength guard rail, with our popular DROP-IN, LIFT-OUT feature.
- Designed for heavy impacts up to 5,000 lbs.
- 4" posts, 18" & 42" high, with 8" x 8" base.
- 14-gage, high-tensile steel rails are 2' through 10' in 1' increments.



**FAST DELIVERY** 

## Wall Bumper Rail

Durable steel protection

- Mounts directly to wall on 16" centers
- 14 gage steel
- 2', 4', 6', 8' and 10' lengths
- Eliminate posts along the perimeter walls.



# Steel bollards



Stand Guard square bollards

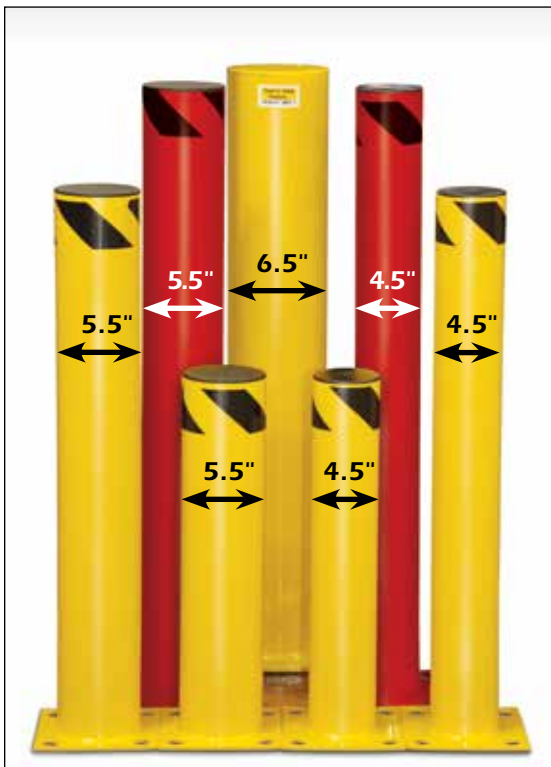

Yellow & red bollards

## Steel Bollards

Steel bollards protect a variety of facility assets.

- Surface mount to concrete or Direct Bury.
- **Economy** 4.5" or 5.5" O.D. 24", 36" or 42" tall, Yellow or Red.
- **Standard** 4.5" O.D. 42" tall, Yellow with black steel cap; or 6.5" O.D. 24", 36" or 42" tall, Yellow or Red with welded top, available with welded eyelet.
- **Direct Bury** 5.5", 6.5" & 8.5" O.D. 84" tall, Yellow or Red.
- **Square Bollard** 4" square tube. 42" tall with painted steel cap.



**We Have Your Bollards! Ready To Ship!**

**FAST DELIVERY** →

SURFACE MOUNT				
OD	HEIGHT	BASE	COLOR	TOP
4.5"	24", 36", 42"	8x8x1/4	Yellow or Red	Plastic cap
4.5"	42"	9x9x1/2	Yellow	Steel cap
5.5"	24", 36", 42"	8x8x1/4	Yellow or Red	Plastic cap
6.5"	24", 36", 42"	9x9x1/2	Yellow or Red	Welded
IN GROUND BOLLARDS				
OD	HEIGHT	BASE	COLOR	TOP
5.5"	84"	NONE	Yellow	OPEN
6.5"	84"	NONE	Yellow	OPEN
8.5"	84"	NONE	Yellow	OPEN



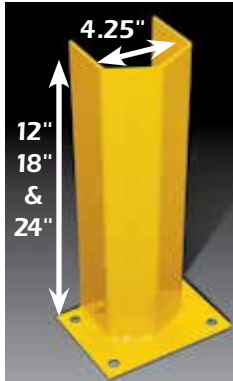

"V" face

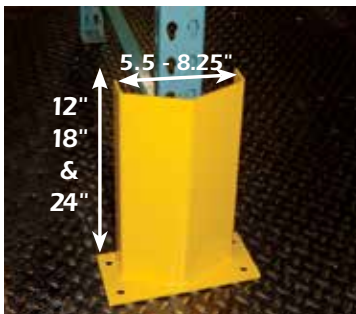

Seismic

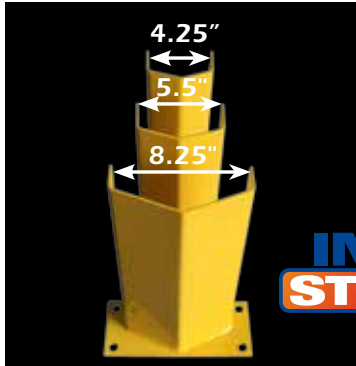

3 different heights & widths



Poly post protector

## Traditional Post Protectors

Traditional style post protection available in a "V" shape or formed face.

- Traditional style with four mounting holes.
- Choose from 12", 18", & 24" tall.
- Clear opening: "V" face is 4¼".
- Anchors available upon request.

## Seismic Post Protectors

Seismic post protectors in "V" face style designed to fit around seismic footplates.

- Clear opening of 5.5" and 8.25".
- Choose from 12", 18" or 24" tall.
- Base plate is 5" deep with four mounting holes.
- Anchors available upon request.



## Poly Post Protector

Easy snap on installation.

- Fits 1 ½" x 3" as well as 3" x3" rack.
- 8" tall x 5 ½" wide.
- Stackable.



# Post protectors

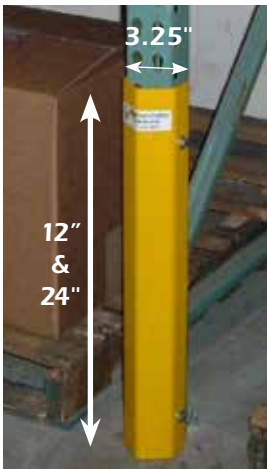

Side mount



Closed top for food industry



flush hardware

## Post Protectors: Bolt On

Bolt-on post protectors add strength to frame column to prevent costly rack damage.

- Available in 24" tall with a clear opening 3".
- $\frac{3}{16}$ " thick wall.
- Includes hardware to attach to rack frame.
- Add strength to your upright.
- Mounting hole inside bull nose.
- Accepts 1/2" anchor.

**In Stock**

## Side Mount Frame Protector

Stop damage at every level.

- Increase frame strength.
- No base plate to interfere when storing pallets.
- 3.25" clear opening.
- 12" and 24" tall with 2" hole spacing.
- Mounting hardware optional.





Outrigger post protector



1/4" or 3/8" in stock



Patented

## Outrigger Post Protector

Designed specifically for Outriggers.

- Choose from 1/4" or 3/8" thickness.
- 4" tall x 3.25" clear, or 5.5" available.
- One mounting hole behind face.
- Accepts 5/8" anchors.



**FAST DELIVERY** 

## Post Protectors: Hidden Anchor

New rack column post protectors eliminate base plates.

- Bolt down model with bracket hardware.
- Energy absorbing design anchors securely in front & behind frame.
- 12" tall by 9" deep.
- Inside dimensions are 5" x 5".
- TAPCON anchors available upon request.





# Column protectors



Slim & short models



Eagle™ – Velcro™ strap

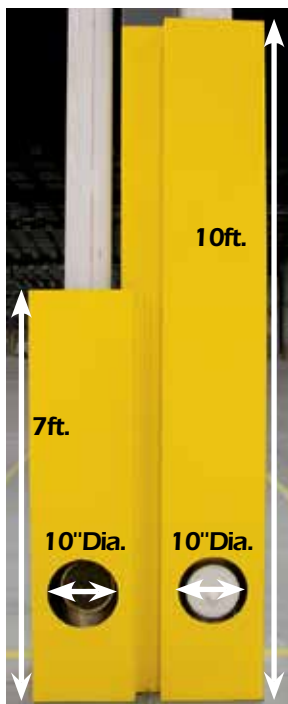
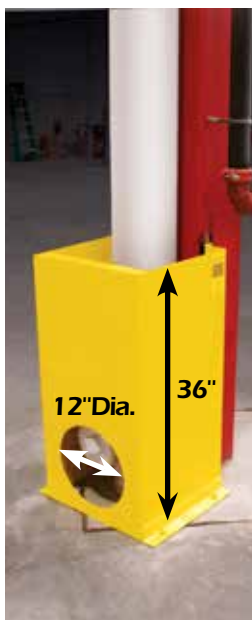

Downspout guards



## Building and Mezzanine Column Protectors

Prevent damage to building support columns or mezzanine columns. From Eagle™ Mfg.

- **SHORT** Model is 24" tall x 24" wide for 6", 8", 10" & 12" columns.
- **SLIM** Model is 42" tall x 12" wide for 4", 5", & 6" columns.
- **STANDARD** Model is 42" tall x 24" wide for 6", 8", 9" Round, 10", & 12" columns. Yellow standard, Lime Green or Orange with reflective tape also available.
- **FASTENERS** Velcro straps.
- **SHIPPING POINTS** Four shipping warehouses.

Style	Eagle™	Colors
SHORT	6", 8", 10", 12"	Yellow, Red
SLIM	4" - 6"	Yellow
STANDARD	6", 8", 9" Round, 10", 12"	Yellow, Orange, Lime Green
FASTENER	Velcro Strap	Black



## Downspout Guards

Prevent costly damage to downspouts.

- Custom made to order, up to 10' tall.
- 7 gage steel construction.
- Available for wall mount.
- Choose with or without floor mounts.
- Optional opening for trap clean-out.
- Powder coated yellow (other colors available).



Seismic option



Half curved end  
(right hand pictured)



Double E.O.A.

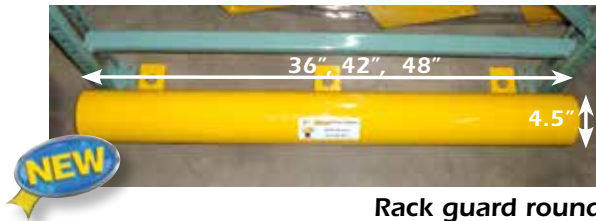

Rack guard round



Custom lengths available



## End of Aisle Rack Protection Curved End

Rack protection creates a visible guide through aisles and saves thousands in damage.

- Available in 36", 42" & 48", single or double ends.
- Custom sizes available.
- Curved end has an 8" I.D. x 12" tall.
- Heavy duty floor angle is 1/2" thick x 6" x 4".
- Available in 3/8" angle.



## Rack Guard Round

Solid welded construction.

- Fits snug to frame.
- 1/2" thick feet fit under rack for tight installation, resulting in a 5" height.
- Accommodates seismic foot plates up to 8" deep.
- 36", 42" or 48" O.A.L., with closed ends.
- Custom sizes available.



# Dock equipment



With and without bevel



Dock monitor

## Door Track Protectors

Door Track protects overhead door track from damage while placing or retrieving pallets.

- Available with or without safety bevel.
- Eliminates expensive service calls for door repair.
- Available without baseplate.
- Standard duty for Fork Truck & commercial applications.
- Full 7" depth, up to 14" available.
- 36" & 48" tall in stock.
- 3/16" thick material, 1/4" available.





Indoor



Outdoor

## Hand Rails

Modular hand rail protects employees from entering areas that are unsafe.

- Rails are powder coated yellow for long lasting durability.
- Easy installation, simply assemble and anchor down.
- Easy replacement of damaged sections or relocation.
- Stocked sizes: 4', 6', and 8' sections; can be cut down in the field.
- Available in any layout, including corners.
- 1.66" O.D., OSHA & IBC compliant.
- 42" tall standard, ADA available.
- Fittings for mezzanine installation available.
- Anchors available upon request.

## Galvanized cast iron fittings



#SYP-12



#SYP-02



#SYP-20



#SYP-03



#SYP-21



#SYP-22



#SYP-04



Indoor or outdoor

## All Welded Hand Rails

All Welded hand rails provide an alternative to the Modular hand rail.

- Rails are powder coated steel for long lasting durability.
- 4', 6', and 8' sections are IN STOCK.
- 2" O.D. Round tube with 6" x 6" x 1/4" base plates.
- Fast, easy installation, just place and anchor down.
- Anchors available upon request.
- Coped midrail, not crushed.



# Safety Swing Gates



Adjustable telescoping design



**IN STOCK**

**NEW**



## Safety Swing Gates

Ideal for stair openings, ladders and platforms.

The "Save"ty Swing Gate bolts to existing rail opening to provide a one-way, self-closing gate. It is a simple and economical solution to comply with OSHA and IBC regulations.

- Designed to fit hand railings.
- Can be modified to fit our guard rail.
- Carbon steel construction (1½" tubing).
- Steel spring for self-closing actuation with adjustment screws that limit swing.

## Telescoping Model

- Adjusts every 2", so you don't order the wrong size.
- Includes a built-in adjustable stop.
- Opens 160 degrees.

**MEETS OSHA & IBC REQUIREMENTS**

Swing Gate No.	Fits Clear Opening	Wing Gate Part #	Fits Clear Opening
<b>SINGLE GATE</b>		<b>DOUBLE GATE</b>	
SYP-PS-15	14" - 17.5"	SYP-PS-9D	16" - 22.5"
SYP-PS-18	17" - 20.5"	SYP-PS-12D	22" - 28.5"
SYP-PS-21	20" - 23.5"	SYP-PS-15D	28" - 34.5"
SYP-PS-24	23" - 26.5"	SYP-PS-18D	34" - 40.5"
SYP-PS-27	26" - 29.5"	SYP-PS-21D	40" - 46.5"
SYP-PS-30	29" - 32.5"	SYP-PS-24D	46" - 52.5"
SYP-PS-33	32" - 35.5"		
SYP-PS-36	35" - 38.5"	<b>TELESCOPING</b>	2' increments
SYP-PS-40	39" - 42.5"	Gate - Adjust 24	17" - 23.5"
SYP-PS-44	43" - 46.5"	Gate - Adjust 36	23" - 35.5"
SYP-PS-48	47" - 50.5"	Gate - Adjust 48	35" - 46.5"

## Standard & Double Gate

- 2.5" adjustability.
- Double Gate has built in stop.
- Standard Gate requires a post for strike plate.
- Opens 180 degrees.
- Available in Stainless Steel or Galvanized.



PickerPal gate



Bumper style



Self-closing gate

## Pallet Safety Gates

Simply forklift your pallet of material through the self-closing safety gates and back away. The gates close up against your material, effectively protecting the mezzanine edge until the pallet is moved past the gates. Then the gates close, all the time protecting the opening.

The adjustable cross bar provides both a visual barrier and a grab surface for added safety.

## PickerPal Gates

- 6 self closing arms, operate independently.
- 6' or 8' width.
- Includes 8' tall rack frames and height limiter.
- MEETS OSHA & IBC REQUIREMENTS.

## Bumper Style Gates

- Standard Sizes: 60" or 72" clear opening width and clear opening height up to 84", includes gate columns, three (3) springs per gate, housed within hinge pivot.
- Teardrop Impact Bumpers: High-impact, ABS bumpers with 3" projection. Black in color.
- Specifications: High-impact, ABS adjustable 4" toe boards.
- MEETS OSHA & IBC REQUIREMENTS.

**Mezzanines?  
We Have  
Gates!**



# Mezzanine gates



Horizontal sliding gate



Vertical lift gate



Pivot gate

## Mezzanine Gates

The Horizontal Sliding Gate and the Vertical Lift Gate are designed to be durable, productive, provide the same protection as your railing systems, and meet federal OSHA requirements for standard railings.

- Easily slides open and closed.
- Manufactured to specific width requirements.
- Factory welded steel framework.
- Gates are 42" high, with one mid-rail and 4" toeboard.
- Electric or pneumatic operation available with remote control. Call for details.
- Easy Installation.



## Pivot Gate

Single or Double width gates.

- All welded tubular steel frame.
- Easily pivots to up or down position.
- Requires only 10-20 lbs. of lift force depending on gate size.
- Made to order to fit your specific opening at no additional charge.
- Can ship completely assembled — simply anchors to mezzanine floor.
- MEETS OSHA & IBC REQUIREMENTS.





Lift Gates: 8', 10' & 12' clear opening



## Dock Door Gates

Ideal for overhead doors. Great visibility to prevent accidents.

The "Save"ty Yellow Dock Gate is fabricated and bolts to post creating visibility. It is an economical and simple solution to comply with OSHA fall protection.

- Available in an 8', 10' and 12' clear opening.
- All sizes in stock.
- 42" tall at top of rail.
- Carbon steel construction (3" tubing) for horizontal rails, which are bolted through a 5" post.
- Air actuation cylinder holds gate open during deliveries or shipments.

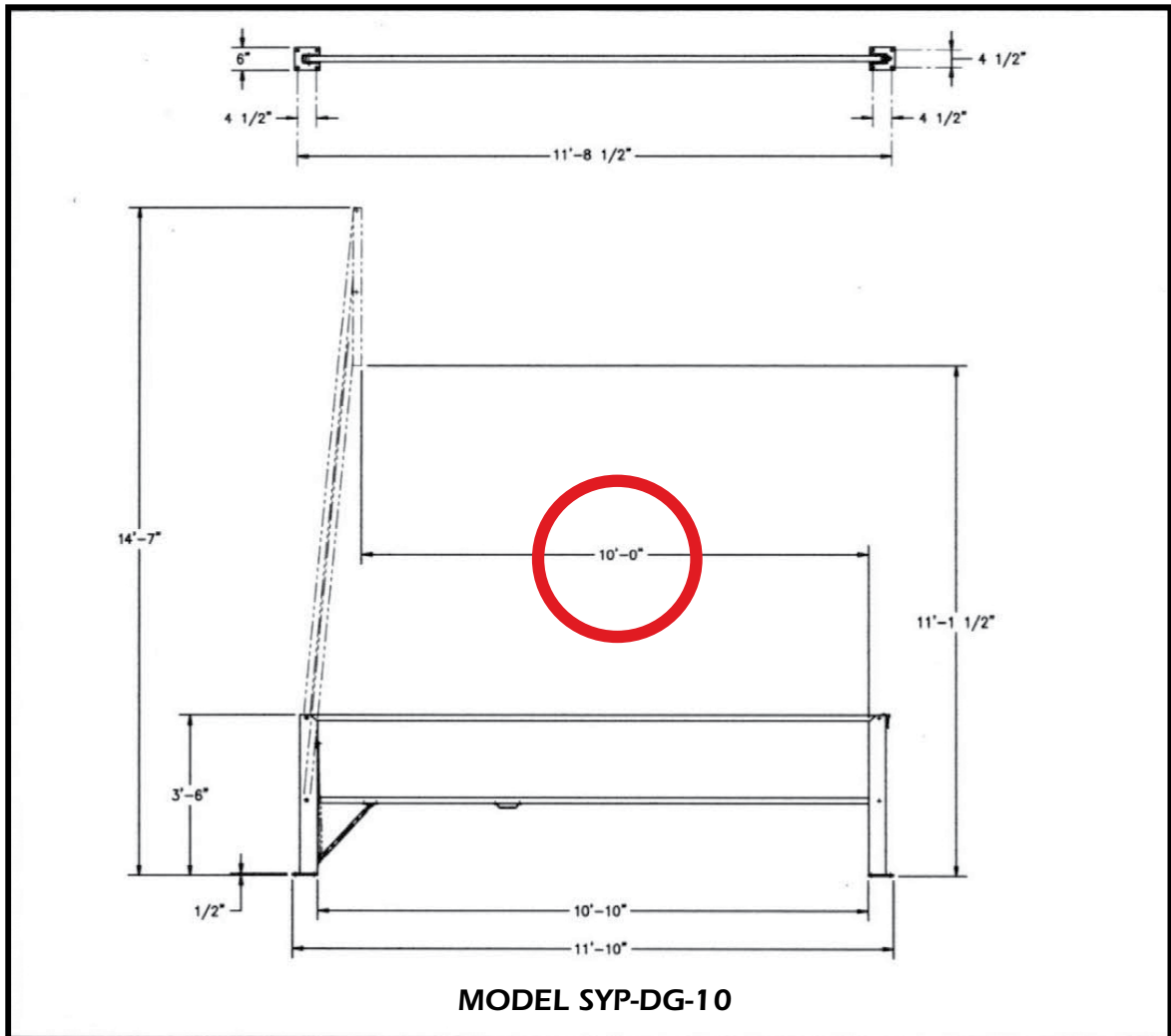



# Dock gates



Rotating gates: widths from 4' to 14'



Driveway rotating gates: widths from 4' to 28'



Open dock



NOTE: Gate sleeve is bollard supported

## Rotating Dock Gate

Provides security, creates awareness and fall protection.

- Mounts over a 42" tall bollard which is required.
- Choose widths from 4' to 14'.
- Install two gates to meet in the center to accommodate space restrictions if needed.
- Add an optional bollard with eyelet at the opposite end for security.

## Rotating Driveway Gate

Provides security, creates awareness and fall protection.

- Mounts over a 42" tall bollard which is required.
- Choose widths from 4' to 28'.
- Install two gates to meet in the center to accommodate space restrictions if needed.
- Add an optional bollard with eyelet at the opposite end for security.

**Gate  
Sleeves Are  
Bollard  
Supported!**



**POWDER  
COATED  
TOUGH™**



**IN**  
**STOCK**



**IN**  
**STOCK**



**IN**  
**STOCK**



**SAFETY PRODUCTS**  
**LEAD FREE PAINT**  
**MADE IN U.S.A.**

## DockPlates and DockBoards

### ALUMINUM DOCKPLATES

Aluminum Dockplates are designed for pallet trucks and non-powered equipment. They come with hand holes for easy moving. Dockplates have an 11" lip with 11° bend standard. Available in 3/8" & 1/2" plate.

### ALUMINUM DOCKBOARDS

Aluminum treadplate with steel side curbs. Dockboards have an 11" lip with an 11° bend. Available in 10,000 lb & 15,000 lb Capacities. Lifting chains are standard.

### ECONOMY STEEL DOCKBOARDS

These 10,000 lb capacity dockboards feature 3/8" steel treadplate with welded steel side curbs. Lifting chains are standard.

### STEEL DOCKBOARDS

Heavy duty dockboard with lifting loops & locking pins. Available in widths up to 78". Capacities up to 60,000 lbs.

### UNIVERSAL STEEL DOCKBOARDS

These heavy duty dockboards are designed for standoff applications where the truck cannot back up all the way to the dock. Dockboards come standard with lifting loops, locking pins and full length pin pockets. Available in widths up to 78" and capacities to 60,000 lbs.

### STEEL RAIL DOCKBOARDS

These dockboards are designed for rail car loading & unloading. Rectangular or flared boards are available in capacities up to 40,000 lbs. Lift loops and spacer rings standard.

CUSTOM MODELS AVAILABLE UPON REQUEST

**POWDER  
COATED  
TOUGH™**

# Lightweight portable dock plates & ramps



SYP-E-1795



SYP-E-1796KIT

Installation Kit



SYP-E-1794



SYP-E-1795CR

## Portable Poly Dock Plates

- Shipped UPS.
- Models 1795, 1796, 1797 for 2 & 4 wheeled dollies.
- 2 integrated handles.
- Aluminum legs.
- Choose 36" or 48" wide by 36" deep.

## Fixed Poly Dock Plate

- Lift-n-lower ergonomic design.
- Molded-in handle.
- Raised non-slip surface and side rails.
- Coated steel kit installs on metal or concrete dock face.
- 6' slide bar for centering & storage.

Model #	Dimensions	Height Diff.	Load	Shipping Weight
SYP-E-1794	27" W x 27" L x 4" H	1	1000	9 lbs.
SYP-E-1795	35" W x 36" D x 5" H	1	750	37 lbs.
SYP-E-1795CR	35" W x 36" D x 6" H	2	750	25 lbs.
SYP-E-1796	35" W x 26" D x 5" H	2	1000	20 lbs.
SYP-E-1796KIT	72" W	5	1000	30 lbs.
SYP-E-1797	48" W x 36" D x 5" H	5	750	40 lbs.

## Poly Curb Ramp

- Use with hand trucks or carts.
- Raised non-slip surface with 1" side rails.
- Integrated handles and 1000 lb. cap.

## Shipping Container Ramp

Has a hook-rail that attaches to the doorkeepers for secure, 3-point contact and support across the width of the ramp & a tab that inserts into the keepers preventing lateral movement during use.

- Ground level entry.
- Use hand trucks or dollies.



# Look out sensors

## FOR TYPICAL FORKLIFT TRAFFIC ALERTS

Each sensor alerts the opposite corner and both sensors can be activated simultaneously. Units include mounting hardware and install in minutes. UL listed for US and Canada. Universal transformers adjust to 24 volts. **LOOK OUT 1 EXTERIOR** has 'daylight bright' lights installed.

### LOOK OUT 1



### LOOK OUT 2



Standard Power Connections



- End of the rack aisles.
- Wall mount for end of aisle obstructions.
- Uses a single set of flashing LED lights.

- An additional set of lights that alternate when activated.
- Units include a 24V dc power pack.

### LOOK OUT 1 EXTERIOR

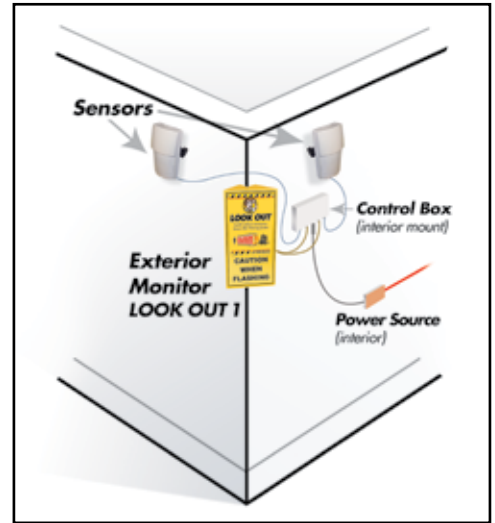

Control Box



Exterior Sensors



- Powder coated stainless steel box for durability.

Product	# of Boxes	# of Lights	# of Sensors	Universal Transformer	Audible	Detection Range
Look Out 1	1	2	2	N/A	Optional	99.9% @35'
Look Out 1 Exterior (Brilliant)	2	2	2	N/A	N/A	99.9% @40'
Look Out 2	1	4	2	N/A	Optional	99.9% @35'



## PRODUCT FEATURES:

- Remote sensor option standard.
- Alerts pedestrians when forklifts are crossing.
- Unit mounts up and out of the way.
- No reflectors required.
- No expensive microwave sensors.
- Nothing attached to your forklifts.
- Low voltage wiring eliminates the need for conduit. 24V transformer plugs into an overhead outlet power source.
- Super bright LED lights with 100,000 hours life.
- Sensors are factory pre-set to monitor from inches to 35' away.
- Audible option for loud environments or outdoors.
- Injuries & fatalities as a result of forklift collisions can be eliminated.
- Optional Universal transformer will handle incoming voltage from 277V to 24V as required.
- Indoor, outdoor and cooler applications.
- Steel powder coated boxes for durability.

### LOOK OUT 3 Rack Mount



Front view



Rear view

- Monitor 3-way intersections and alert all directions.
- Two sensors monitor the main aisle while a third monitors the row that meets the main aisle to provide an alert in 3 directions.
- 25' standard cable.

### LOOK OUT 2, 3 & 4 Hanging Mount



- For 2, 3 or 4-way intersections to monitor and alert all directions.
- Sensor range is 35' away and 40' wide, adequate distance to stop a fork truck traveling at OSHA recommended speeds.

Product	# of Boxes	# of Lights	# of Sensors	Universal Trans- former	Audible	Detection Range
Look Out 2 (Large Box)	1	2	2	Optional	Optional	99.9% @35'
Look Out 3 (Rack Mounted)	1	1 set & 2 large	3	Optional	Optional	99.9% @35'
Look Out 3	1	3	3	Optional	Optional	99.9% @35'
Look Out 4	1	4	4	Optional	Optional	99.9% @35'

## Application Photo Gallery

Applications are endless when you consider the amount of valuable assets that need protection.

Our products are securing many areas and are standing guard to protect the facilities and employees of small, medium and large corporations.

If you have an application that you would like to discuss, we will help you find the best solution to fit your needs. We have the experience and resources to assure that you and your facility will remain protected.

At "Save"ty Yellow Products it's our mission to help SAVE YOUR ASSETS!



Guarding equipment



Door track guards



Guarding overhead conveyor



Dock gates



Guarding electrical panels



Protecting rail dock



# Our products at work:



Protecting traffic lane



Lite duty



Guarding battery racks



Rack guard round



## New Dealers Welcome!

**W**hile we have many dealers around the country, there's room for more! As a **"Save"ty Yellow Products** dealer you can expect sales support in a number of ways.

- ✓ **"Save"ty Yellow Products** has manufacturer's reps who can provide sales training as well as help with specific applications.
- ✓ Literature is available, both in print and pdf files.

- ✓ A Power Point presentation is available for dealer use.
- ✓ A professional web site is maintained.
- ✓ Our products are advertised nationally.

Call for more information or for a quote. We are always open to discuss special applications.

**"Save"ty Yellow Products** reserves the right to make product improvements and changes without notice.





# Yellow Products

TOLL FREE: 877-728-3891 ▪ Local: 630-293-8013 ▪ Fax: 630-876-1993  
1319 Howard Drive ▪ West Chicago, IL 60185 ▪ sales@save-ty.com  
www.save-ty.com



See page 3



Ask about our butt muffler



See page 12



See page 9



Safety Belting now available



See page 6



See page 4



See page 10



See page 5



See page 17



See page 10

Authorized Dealer:



**ADVANCED**  
EQUIPMENT COMPANY